

Original Article

# India's IOT-Based Smart Milk Society System

Ravi Gengappa

Department of Computer Engineering, Amrita Vishwa Vidyapeetham, Mysore Campus, India.

Received Date: 28 March 2023

Revised Date: 12 April 2023

Accepted Date: 16 April 2023

**Abstract:** India is mostly an agricultural nation. Since there is such a large distribution of milk in a country with an agricultural economy, quality control and distribution are challenging. The IoT-based Smart Milk Society System has been offered as a solution to the aforementioned problem. This device automatically distributes the amount of milk after analysing its quality [2]. The system consists of three mild steel modules made up of Inlet, Storage, and Outlet. The first module is divided into two segments: a sensor unit and a control unit. The sensing unit of the module, which is located in the first section, has sensors built in to measure the pH, SNF, and aroma of the milk. [5]. The ESP 32 NODE MCU [6], which controls the entire system, is part of the second section, which serves as the control unit. The proprietors receive the sensing values via IoT and can view them on the BLYNK app. The second module is a storage unit with a level sensor. RFID is installed outside the outlet container, while the solenoid valve, a relay, and other components are installed within. When the RFID is turned on, the necessary amount of milk is automatically dispensed. [1] The aforementioned system is utilised by societies in real-time applications.

**Keywords:** Quality of Milk, Sensing Unit, Control Unit, IoT, ESP 32 Node MCU, pH, SNF, Aroma, RFID.

## I. INTRODUCTION

The majority of the dairy business in India is cooperative. Milk and dairy products are very important. As more individuals deposit milk in the dairy, it becomes increasingly difficult for the dairy to assess the quality of milk from each person in accordance with government requirements for calculating milk quality and quantity and granting compensation. The fact that over 550 tons of milk were produced globally in 2017 compared to 482 ton's in the preceding three decades. The increase in milk production and demand, from million tonnes in 1982 to 754 million tonnes in 2012, is evident. The IoT-based smart milk society system was created to address the aforementioned problem.

The Internet of Things (IoT) is a network of connected, registered objects, machinery, and electronic devices, as well as objects, creatures, and people. These objects have unique identifiers (UIDs), which allow them to transfer data over a network without the need for human-to-human or human-to-PC communication. An online network of intelligent appliances, sensors, and actuators is known as the internet of things (IoT). The Internet of Things (IoT) in the embedded sector is rapidly developing. The opportunities for intelligent dairy farming are rising thanks to the Internet of Things (IoT) and data-driven techniques. The demand for milk is rising continuously as a result of the expanding global population. Dairy products are consumed more frequently in industrialised nations than in developing nations. To meet this rising demand for milk products, more advanced technical solutions must be developed to improve milk validity. The use of IoT and other strategies is intended to assist a farmer in getting over some of the challenges associated with traditional farming and boost milk output.

The ESP32 is used in this project to create a milk quality monitoring gadget. [3]. The ESP32 module is an inexpensive board with a sizable and expanding community. IoT interfaces are simple to create. A variety of sensors can connect with the ESP32. The ESP32 has access to a virtually endless supply of knowledge, all of which has been made possible by the great community support. In order to assure a healthy final product, use a sensory method to evaluate the quality of milk early on. In this study, the quantity and quality of milk are examined. The IoT platform used for milk products is real-time, code-efficient, and less complex. The milk system is employed in real-time applications for societal functions, and it has a significant impact.

## II. PROPOSED METHODOLOGY

The idea of using electronic sensors to identify adult milk has been the main focus of the project's development. This study demonstrates a ground-breaking method for autonomously analysing the quantity and quality of milk, which decreases labour requirements, improves accuracy, and saves time. pH, Aroma, and SNF are the quantitative and qualitative parameters that were computed using this technique. The system created is really fragile. The constructed device is smaller



and lighter in size. It is energy- efficient and reacts rapidly. In the current setup, time consistency can be easily detected. The project's objective is to use electrical sensors to measure both the quantity and quality of milk. The database for the mobile application will be updated with all of the milk's information.

**A. Block Diagram**

A microprocessor, an ultrasonic sensor, a pH sensor, an RFID card reader, an RFID tag, a relay, and integrated solenoid valves make up this system. Given that embedded systems may only benefit from advantages like size, weight, power consumption, and speed, the ESP32 Node MCU was chosen for manufacture. The quantitative and qualitative parameters that were calculated utilising this method were pH, Aroma, and SNF. Once the milk has been put into the tank, the ultrasonic level sensor counts the quantity.

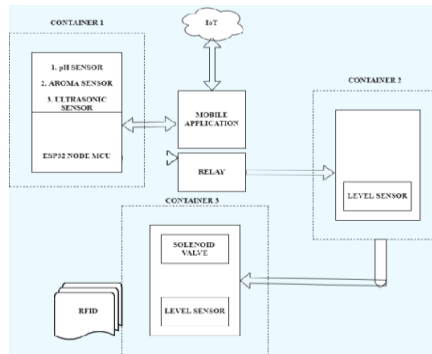

**Figure 1: Block diagram**

The quality of the milk is assessed by the pH sensor, and then it is separated into different groups in accordance with that quality. The solenoid valve and relay are connected. The first RFID tag is punched in module 3 and attached to the RFID card reader. The programme dumps information about the user, such as their name and unique code. The milk is divided using three solenoid valves. The solenoid valve opens in response to the pH level, dispensing milk into the tank. One may use a smartphone to assess the milk's quality. The quantity of milk and pH level are used to calculate the price. The database is used to store each person's information, which is then used to determine the overall amount at the end of the month. The switch for the desired milk quality is chosen by the client. The customer will get the milk of the appropriate quality from the tank after the procedure is complete.

**B. Circuit Diagram**

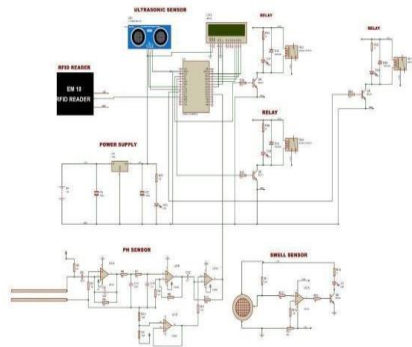

**Figure 2: Circuit Diagram**

**C. ESP 32 NODE MCU**

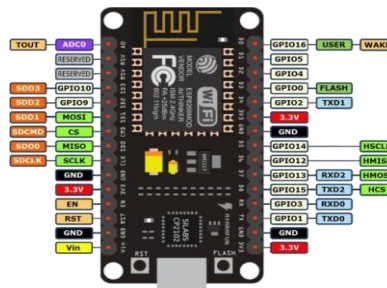

The ESP32 Node MCU, a self-contained SOC with a built-in TCP/IP protocol stack, enables any microcontroller to connect to your Wi-Fi network. Either a programme may be hosted on the ESP32 or another application processor can handle all Wi-Fi networking functions. All you have to do to gain almost as much Wi-Fi capability as a Wi-Fi Shield is attach an ESP32 module to your IoT device since each one already has AT command set software pre-programmed. The ESP32 module is a large, expandable board that is very inexpensive. Our system uses the ESP32 Node MCU to control the whole system. thanks to the simplicity with which any device with Wi- Fi capability may connect to the ESP32 Node MCU and interact with IOT without first connecting to the network.

**D. pH Sensor**

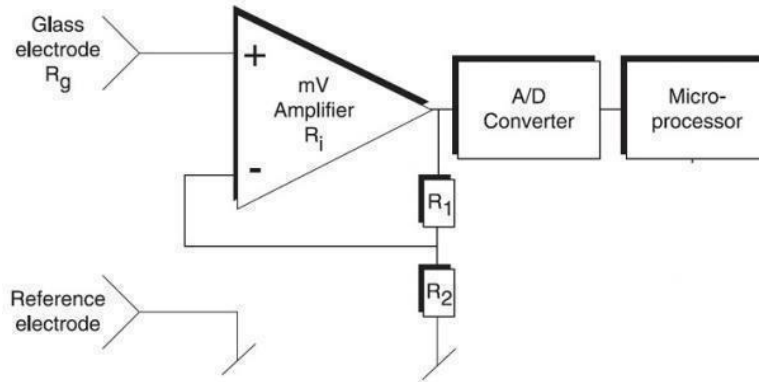

**Figure 4: Inner Block of pH**

The pH level is determined using the PH electrode. It produces the appropriate voltage signal in accordance with the PH level of the milk. This voltage signal is increased by the operational amplifier because it is in the mV range. The operational amplifier OP07 is used to build the amplifier. The operational amplifier's inverting input terminal receives the signal after it has been amplified. The amplifier is constructed using an LF356 operational amplifier. The +12v to -12v reference signal is then produced by the pair of diodes D1 and D2, which are attached to non-inverting input terminals. The filter component receives the output signal after it has been filtered to remove noise. The filter component is composed of the operational amplifier LM324 and the capacitors C1 and C2. The final voltage is fed through a gain amplifier with a variable resistor in the feedback route after the noise-free signal is passed to a comparator, where the pH level is compared to a reference level. The final gain voltage is then supplied to the matching circuit to ascertain the pH level in the milk. The pH level is then transmitted to the ESP 32 controller after that. IoT is used to view the pH levels through a mobile app.

**E. Measurement of SNF**

The milk's proteins, lactose, minerals, acids, enzymes, and vitamins are referred to as solids-not-fat (SNF). The total solid content is the total solid content less the fat content. Total milk solids are calculated by combining fat and SNF. The formula below can be used to determine the SNF.

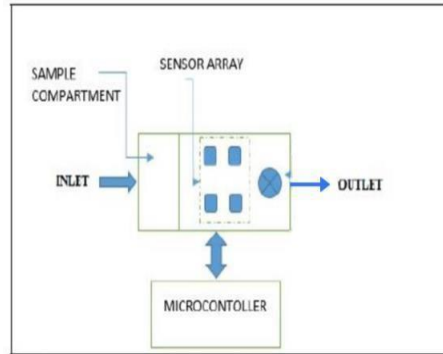

**Figure 5: Experimental Setup**

$(Fat \times 0.21) + (CLR \text{ reading} / 4) + 0.36$ . Using a common lactometer and the specific gravity principle, the CLR is computed. A glass tube with lead or mercury injections is located at the lactometer's base. Pure milk has a specific gravity that ranges from 1.026 to 1.028. Milk's water content can be calculated using its specific gravity.

A circular plate attached to the lactometer's neck serves as a reference for the ultrasonic sensor while it is submerged in milk. The output of the ultrasonic sensor is impacted by the change in the distance of reference caused by the milk's fluctuating specific gravity. As a result, the output voltage of the ultrasonic sensor is proportional to the specific gravity of the milk (water content). The Ultrasonic sensor is calibrated using pure milk. The output voltages are then measured by repeatedly adding a known quantity of water. The typical FAT and CLR readings from the lactometer are used to calculate the SNF.

**F. Aroma Sensor**



**Figure 6: Block Diagram of Aroma Sensor**

Many times, aroma sensors are designed to detect a certain odour in electrical equipment. Dynamic dilution olfactometry analysis is widely used to measure odours. Establishing the olfactory perception threshold for a gaseous sample is the goal of olfactometry analysis. The number of dilutions at which half of a jury recognises the odour but not the other half is known as the olfactory perception threshold. During this procedure, the odour's quality is not assessed. The notation "1 o.u./m3," which stands for one odour unit per cubic metre of air, is used to indicate the olfactory perception threshold. When molecules of any chemical element are deposited on the surface of the scent sensor, it begins to function. When a sensor is exposed to odours, its resistance varies, and this change is seen. The outcome is a pattern unique to that element. Odor sensing is this system's primary function.

**III. RESULTS**

Milk is a rich source of vitamins and minerals, particularly calcium. On bone health, it has a big effect. A balanced diet should include milk and other dairy products like yoghurt and cheese every day, advises a dietitian. The resultant values in our system are seen using a mobile app. The resulting results display a range as well as typical and exceptional situations, such as os and 1. Using this technique, people become more productive.



**Figure 7: Result of the System**

**IV. CONCLUSION**

The designed structure is lighter and more compact than the traditional framework. It responds quickly and uses little energy. Therefore, real-time applications are suitable for it. The owner will monitor the parameters' outcomes using a smartphone application. The system's overall consistency will be the focus of next investigations. Additionally, efforts should be made to enhance the apparatus's usability. The suggested system includes basic components like sensors and Node MCUs since they are well-coupled and aid in dairy automation.

## V. FUTURE SCOPE

Dairy consumption will increase because it provides essential nutrients more effectively than many other agricultural systems. Mechanization of dairy farming will occur in developing nations, while those with sophisticated dairying systems will see a doubling of milk yield per cow. Technology that combats fake money can be added to the aforementioned technique in the future to improve it.

## VI. REFERENCES

- [1] Chakurkar, Priti, Sajeeda Shikalgar, and Debajyoti Mukhopadhyay. "An Internet of Things (IOT) based monitoring system for efficient milk distribution." 2017 International Conference on Advances in Computing, Communication and Control (ICAC3). IEEE, 2017.
- [2] Mate, Sanjay, Vikas Somani, and Prashant Dahiwal. "Design and Development of IoT-Based Intelligent Solutions with Blockchain for Indian Farmers on Livestock Management." Proceedings of the International Conference on Intelligent Technologies in Security and Privacy for Wireless Communication, ITSPWC 2022, 14-15 May 2022, Karur, Tamilnadu, India. 2022.
- [3] Saravanan, K., and S. Saraniya. "Cloud IOT based novel livestock monitoring and identification system using UID." Sensor Review (2017).
- [4] Yan, Shu-Rong, et al. "Implementation of a Product-Recommender System in an IoT-Based Smart Shopping Using Fuzzy Logic and Apriori Algorithm." IEEE Transactions on Engineering Management (2022).
- [5] Harshitha, M., et al. "An Intelligent and Smart IoT-Based Food Contamination Monitoring System." Proceedings of International Conference on Computational Intelligence and Data Engineering. Springer, Singapore, 2021.
- [6] Jindal, Harsh, et al. "IoT Based Smart Agriculture: A Study." i-Manager's Journal on Information Technology 10.1 (2020): 31.
- [7] Naujokienė, Vilma, et al. "Climate-Smart Holistic Management System Criteria's Effectiveness on Milk Production in Lithuania." Agriculture 12.6 (2022): 804.
- [8] Hussain, S. Asif, et al. "Milk products monitoring system with arm processor for early detection of microbial activity." 2016 3rd MEC International Conference on Big Data and Smart City (ICBDSC). IEEE, 2016.
- [9] Bhoj, Suvarna, et al. "Smart and Automatic Milking Systems: Benefits and Prospects." Smart and Sustainable Food Technologies. Springer, Singapore, 2022. 87-121.